



JAN PLECHÁČ & HENRY WIELGUS

BUMP

credenza  2018

LA RICHESSE DES MATERIAUX

Bump est une collection de buffets mêlant métal galvanisé et marbre. La galvanisation est un procédé qui permet de protéger les métaux des substances corrosives traditionnellement utilisés dans les secteurs d'industrie lourde. L'acier est submergé dans un bain de zinc en fusion. La réaction chimique qui en découle fait naître des teintes iridescentes et ces motifs uniques.

« Le marbre est un matériau unique : chaque bloc extrait de la montagne révèle un dessin et une texture exceptionnels. Nous souhaitons reproduire cette imprévisibilité et cette richesse via un processus et des matériaux industriels. La galvanisation du métal nous a permis d'obtenir ce résultat riche et inattendu qui fait de chaque meuble une pièce unique. »

Les designers Tchèques Jan Plechac et Henry Wielgus ont présenté le premier prototype de Bump à l'espace Rossana Orlandi lors de la design week de Milan en 2016. Cette première pièce a été le point de départ d'un travail de deux ans avec La Chance afin de développer la collection de cabinets et crédences Bump. Le résultat est un meuble conceptuel mais néanmoins raffiné, caractérisé par la bosse dans le métal - le bump - qui permet d'ouvrir le meuble d'une légère pression.

THE RICHNESS OF MATERIALS

Bump is a collection of cabinets in galvanized steel and marble. The name comes from the 'Bump' on each door where you push to open the doors.

Galvanization is a process traditionally associated with heavy industry and used to protect metals against corrosive substances. Steel is submerged in a bath of protective molten yellow zinc which creates this unique iridescent colour and shades.

"Marble is an incredibly rich material and every time you extract a block from the mountain you have the surprise to discover an incredible design. Even each slice is different. We wanted to replicate this unpredictability and richness with an industrial material and process. Galvanization produces this kind of rich shades and elaborate design". The shape remains simple and Bump is all about the materials. The structure and interior of Bump is entirely made of wood and metal is only applied as a décor to this conceptual but nonetheless refined piece.

A Bump prototype was first presented at Spazio Roanna Orlandi in Milan 2016 by Czech Designers Jan Plechac & Henry Wielgus. This piece was the base concept for a 2 years work between La Chance and the designers to develop the Bump collection of credenza and cabinets.



JAN PLECHAC & HENRY WIELGUS

BUMP 2

Credenza ● 2018



MATERIALS & FINISHES

FINISHES	
	White Pele de tigre marble
	Black Marquina marble
	Black MDF

MATERIALS

- Marble
- MDF
- Galvanized doors & side

DIMENSIONS & WEIGHT

	BUMP	WITH PACKAGING
HEIGHT	61,5 or 91,5cm / 24 or 35,4in.	53x98,2x53cm / 20,8x38,7x20,8in.
WIDTH DEPTH	90,2cm / 35,4in. 45cm / 17,7in.	53x98,2x7,5cm / 20,8x38,7x2,8in. 76,2x21/51x41cm / 30x8,3/20,1x16,1in.
WEIGHT	52 to 54kg / 114,6 to 119lbs.	58 to 60kg / 127,9 to 132,3lbs.

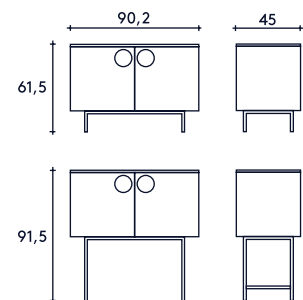

OTHER DETAILS

TECHNICAL INFORMATION	Delivery : 8 weeks Marble is a natural product. Shade and pattern may vary between two credenzas.
PACKAGING	1 wooden crate, 1 cardboard box and feet wrapped in foam.
MAINTENANCE	Always use a microfiber cloth and rub lightly. Never apply any solvents.

JAN PLECHAC & HENRY WIELGUS



BUMP 4

Credenza ●● 2018



MATERIALS & FINISHES

FINISHES

-  White Pele de tigre marble
-  Black Marquina marble
-  Black MDF

MATERIALS

- Marble
- MDF
- Galvanized doors & side

DIMENSIONS & WEIGHT

	BUMP	WITH PACKAGING
HEIGHT	61,5cm / 24in.	53x188,6x53cm / 20,8x74,3x20,8in.
WIDTH	180,6cm / 70,9in.	53x188,6x7,5cm / 20,8x74,3x2,8in.
DEPTH	45cm / 17,7in.	143,4x21x41cm / 56,5x8,3x16,1in.
WEIGHT	105kg / 231,5lbs.	127kg / 280lbs.

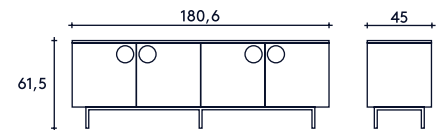

OTHER DETAILS

TECHNICAL INFORMATION	Delivery : 8 weeks Marble is a natural product. Shade and pattern may vary between two credenzas.
PACKAGING	1 wooden crate, 1 cardboard box, and feet wrapped in foam.
MAINTENANCE	Always use a microfiber cloth and rub lightly. Never apply any solvents.



The designers

Jan Plechác and Henry Wielgus met during their studies at AAAD (The Academy of Art, Architecture and Design in Prague) where their first collaborations began. After Jan Plechác exhibited his thesis work at Salone Satellite 2011, he gained much attention from galleries and well-known manufacturers. For his work he has been awarded the title of Discovery of the Year, during the Czech Grand Design Awards as well as the Elle Décor International Award. In 2012, Jan Plechác and Henry Wielgus founded studio Jan Plechác & Henry Wielgus together, whose work transcends the barriers between art, architecture and design. Currently, studio Jan Plechác & Henry Wielgus is commissioned for international re-known galleries and brands such as Rossana Orlandi Gallery, Mint shop, Luminaire, Lasvit, Cappellini or Menu.

La Chance

La Chance is a Paris based design company producing furniture, lighting, accessories, rugs and wallpaper with a strong and distinctive style. La Chance gives a contemporary interpretation of the ornamental and decorative French furniture tradition rooted in the Art Deco period. The creations of La Chance share a sophisticated, rich and singular design based on noble materials. It is a come back to a warm and uninhibited luxury, breaking away from cold and conceptual design. La Chance produces investment pieces that will get a patina for the future generations to keep enjoying this contemporary family furniture.



La Chance

21, rue Michel le Comte 75003 Paris FRANCE
+33 (0) 9 72 31 12 74 info@lachance.paris
www.lachance.paris